



May 2008 Cushioning Achievements

Partners involved
UPC – LABSON
IMAMOTER
ROQUET

PROHIPP is a project partially financed by E.C. (www.prohipp.com)

Information contained in the present document reflects only the opinion of the author





Cushioning type III By tapered element

Principle of operation
is widely known
Design improvement
by “trial an error
methodology”

Prohipp has
developed some
modifications of this
known principle of
operation, basically to
validate the prediction
models and improve
the reversal start up
of the cushioning

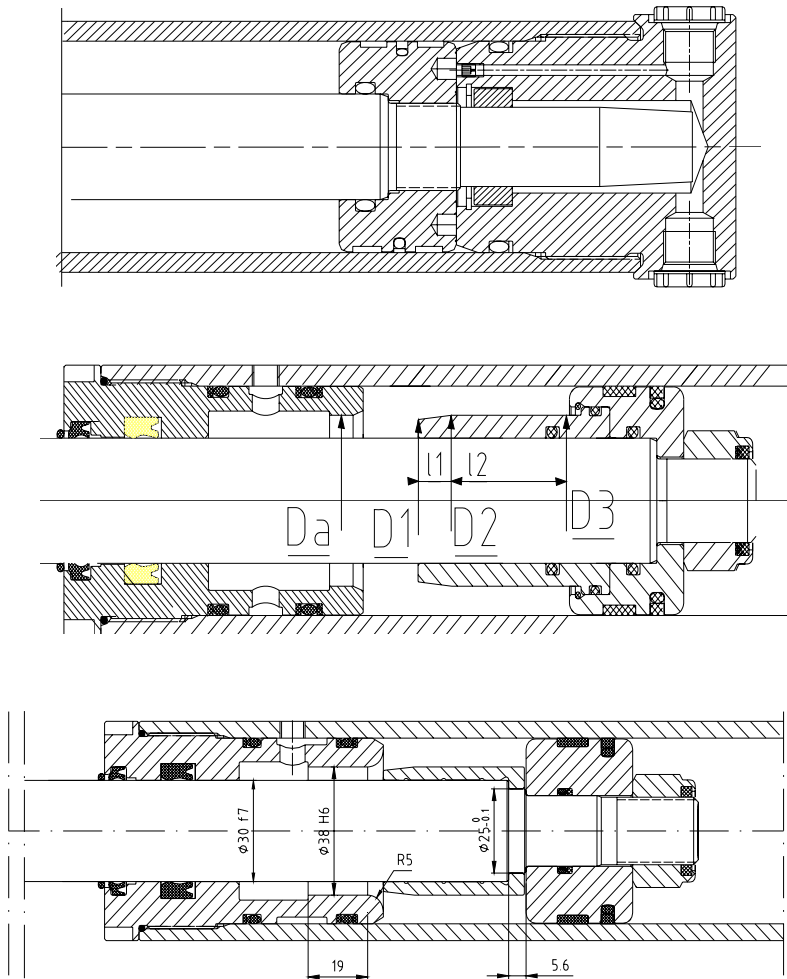

Several models to predict and
improve the characteristics has been
developed by LABSON , IMAMOTER ,
ROQUET



ROQUET - COORDINADOR

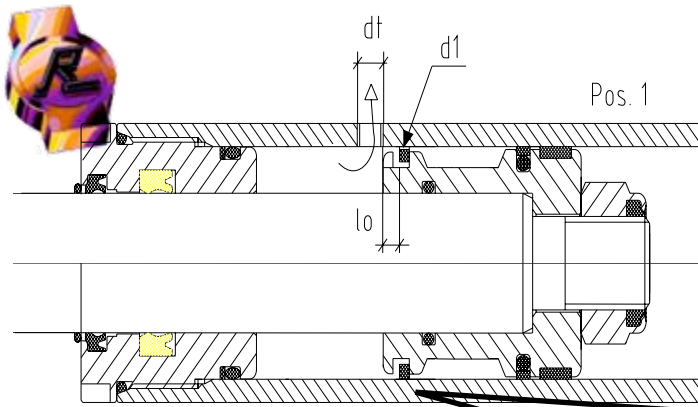

Cushioning type II
By Floating Metallic ring :
Design from an old patent already expired

Cushioning was by a small slot machined in the metallic ring
 The cushioning effect was rather brusque a non progressive

Its main advantage was an original system to solve the reversal start up of the cushioning by means of the floating ring

In the project we work to have a more progressive and predictable cushioning behaviour

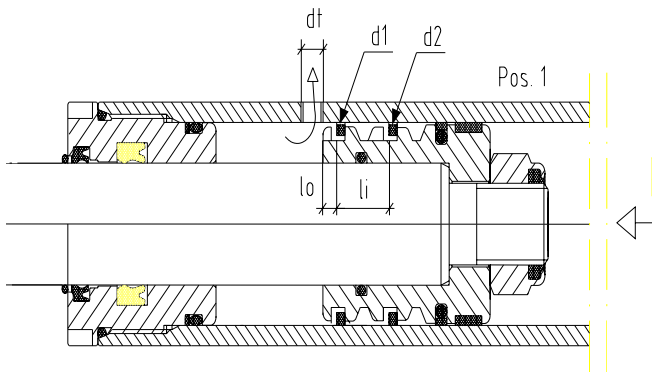

a) By means of a double metallic ring

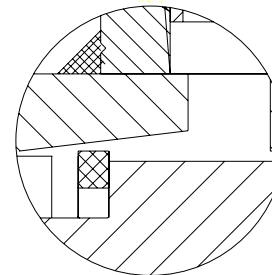

b) Translating the cushioning effect from the small slot in the metallic ring to a progressive slot machined directly on the tube



Cushioning type I

By grooves machined directly on the piston

Rectangular grooves:
(two dimensions to control)
1-2 grooves in front of the port

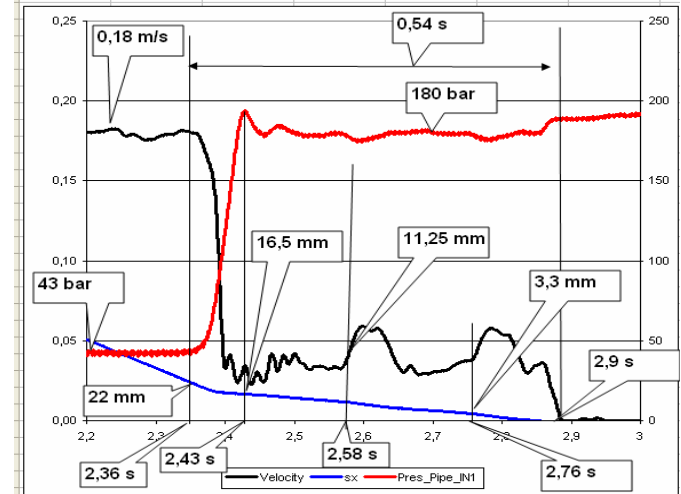
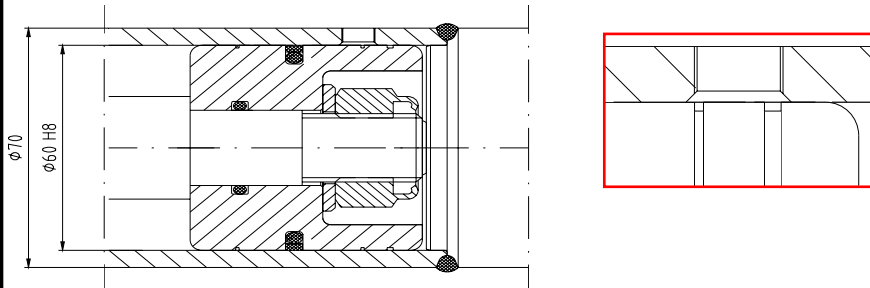

IMPROVEMENT

Triangular grooves:

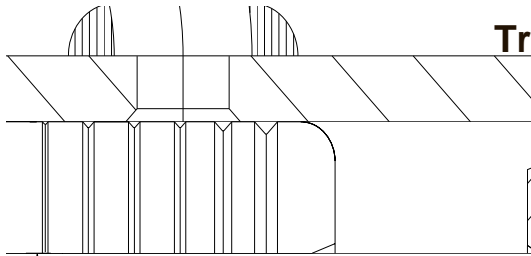

More reliable to manufacture

2 / 3 grooves in front of the port:

Smoother cushioning

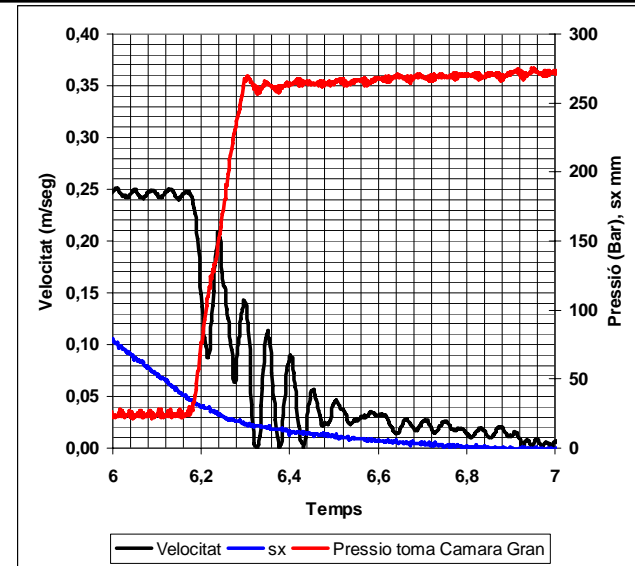

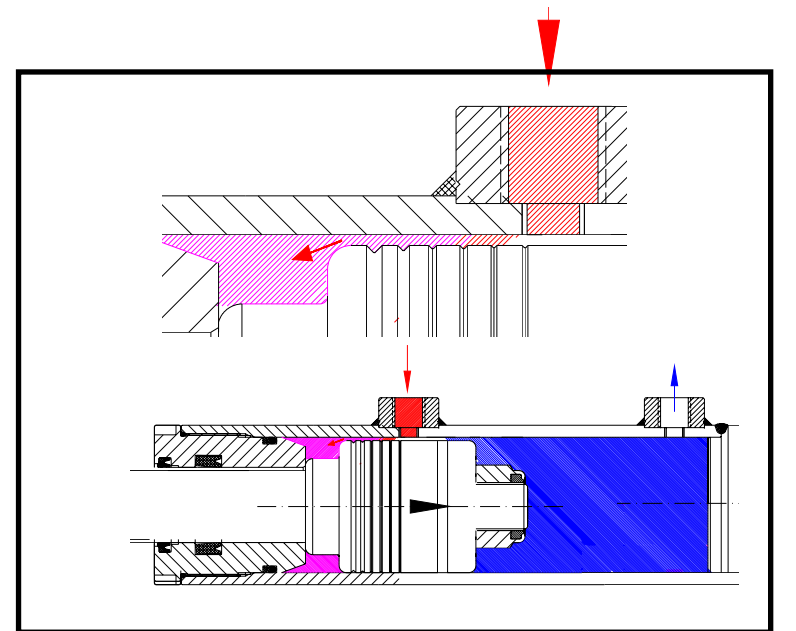
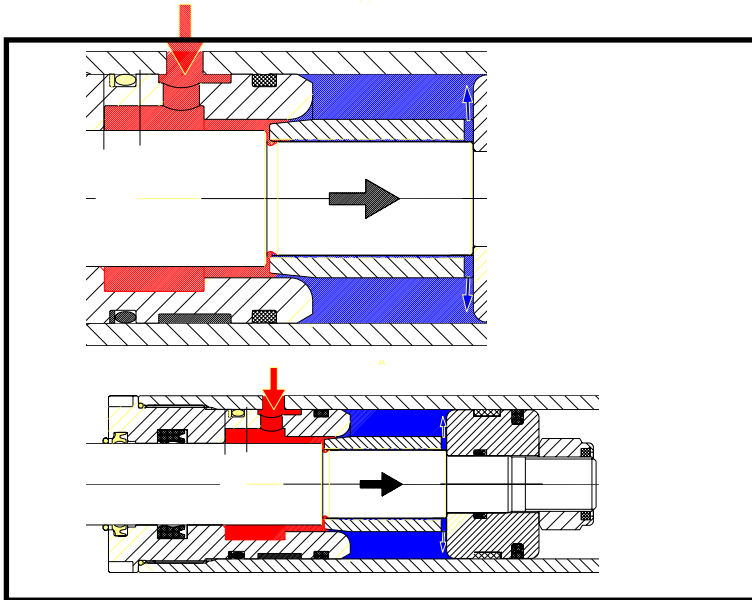
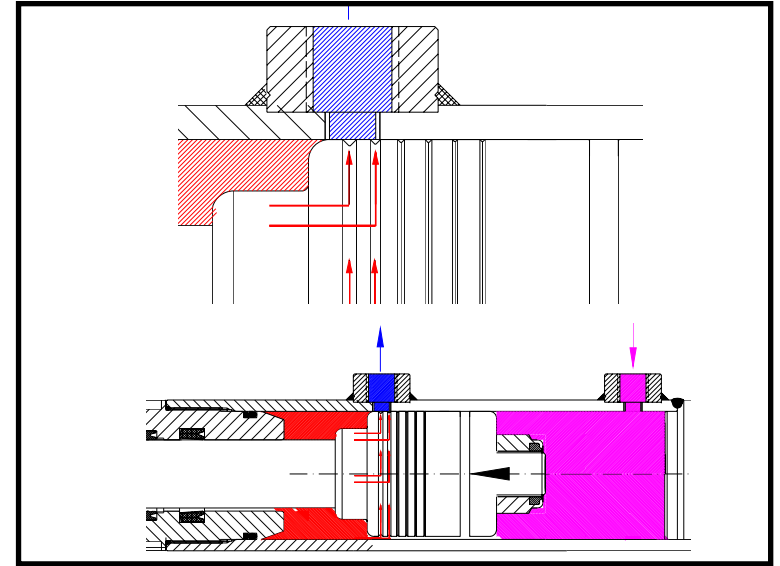
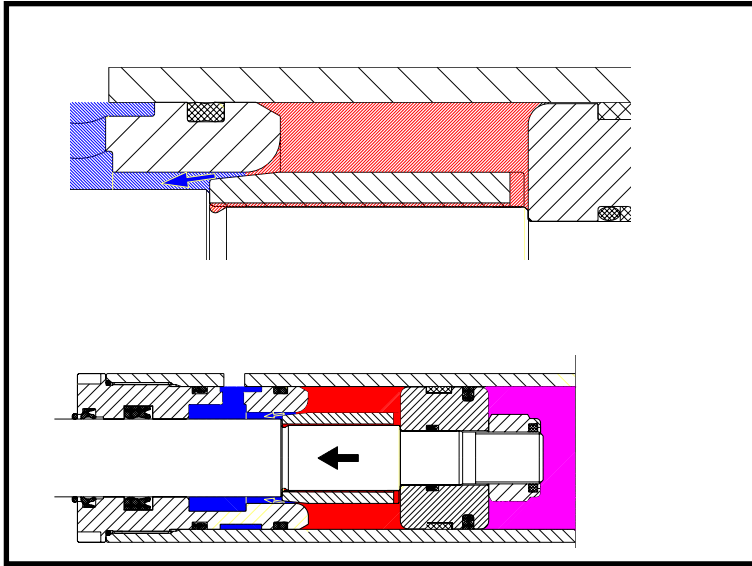

ROQUET - COORDINADOR

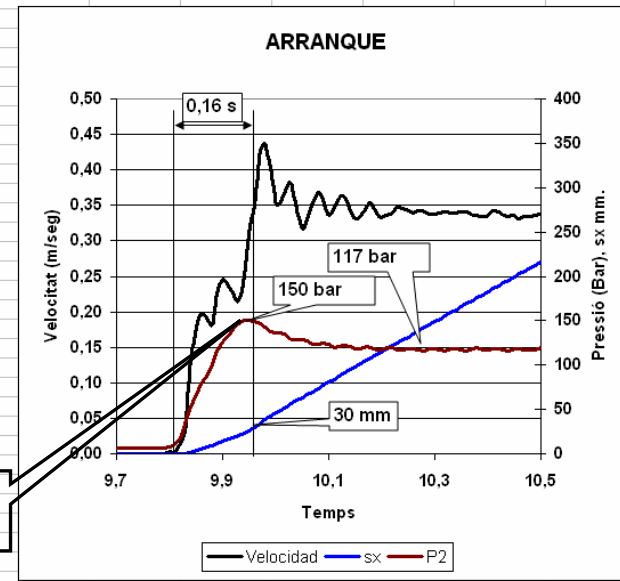
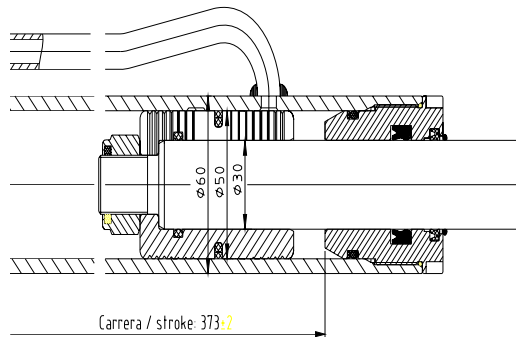
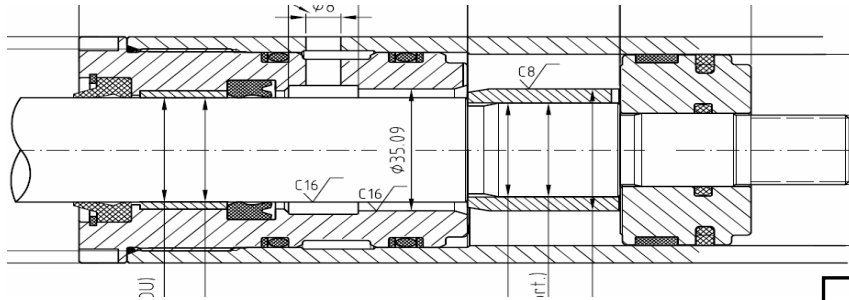

150

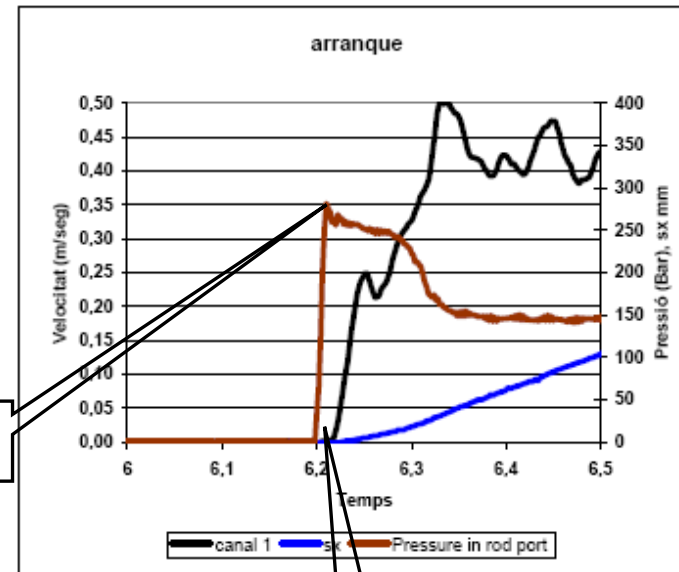

270

DELAY



Cushioning SIMULATION



State of the art

- Basically trial- and error methodology
- Bath university presented some papers about conical simulation, (type III) , but supposing a perfect centred one , which is not the real behaviour normally
- Rectangular, piston grooves are seldom use and known, no studies about it. (type II)
- Triangular , piston grooves, are absolutely unknown and no studies on it (type II)
- Cushioning by metallic ring no simulation studies at all

ACHIVEMENTS

- For all the 3 types of cushioning, simulation computer programs has been developed, by IMMAMOTER ; UPC-LABSON, and ROQUET.
- The programs tries to consider the effects of misalignments that in a real production cylinder may occur.
- Also the bell effect of the type I has been experimentally researched and included in the simulation model.
- (This phenomena has never been described, end studied before)

TIME OF CUSHIONING
(triangular grooves)

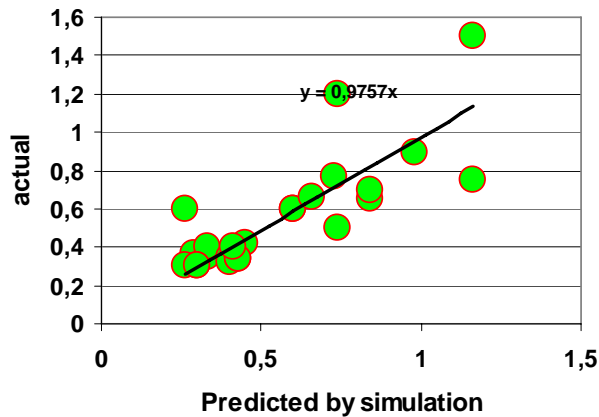

SIMULATION- (Triangular grooves)

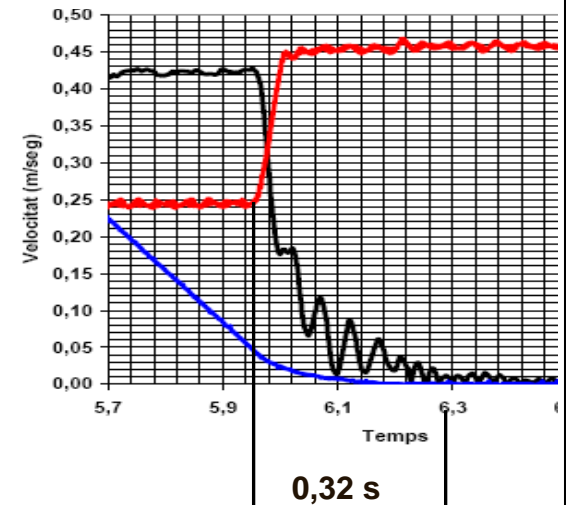
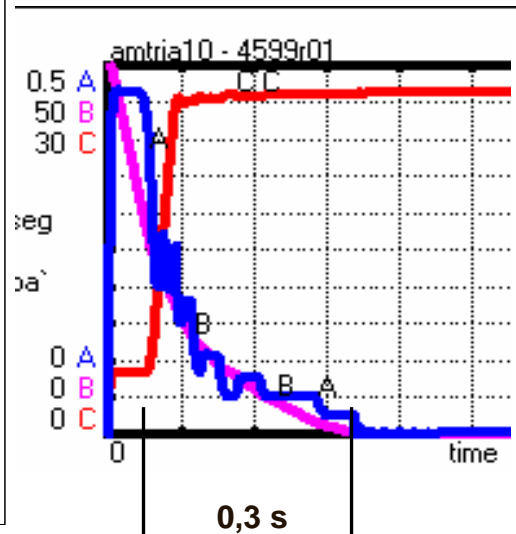



Thanks for your attention



ROQUET - COORDINADOR